

Functional Block Diagram

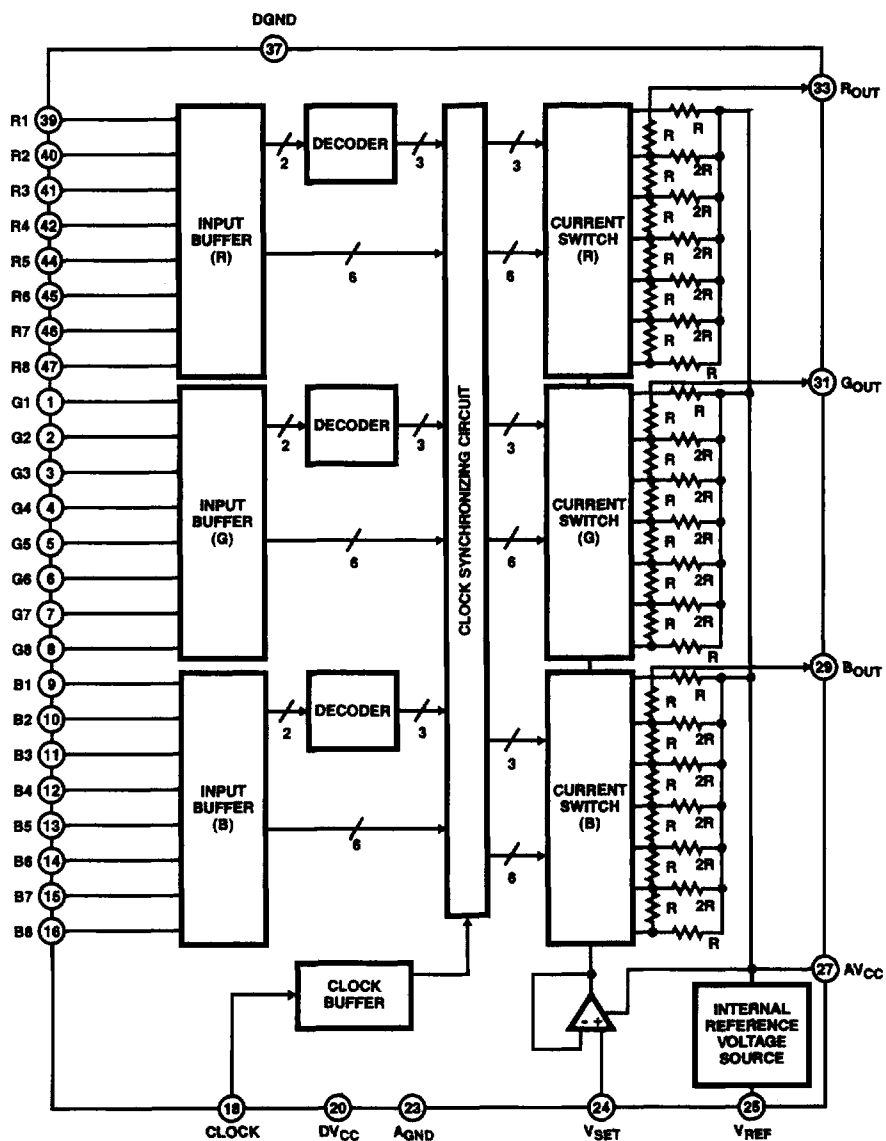

Pin Descriptions

NUMBER	SYMBOL	EQUIVALENT CIRCUIT	DESCRIPTION
1 to 16 39 to 42 44 to 47	R1 to R8 G1 to G8 B1 to B8		Digital Input pin. From pins 39 to 42 and from 44 to 47 are for RED. R1 is MSB and R8 is LSB. From pins 1 to 8 are for GREEN. G1 is MSB and G8 is LSB. From pins 9 to 16 are for BLUE. B1 is MSB and B8 is LSB.
18	CLK		Clock Input pin.
20	DVCC		Digital V _{CC} .
17 21 to 22	NC		Vacant pin (no connection).
23	AGND		Analog GND.
24	VSET		Bias Input pin. Normally, apply 0.87V. See "Note on use."
25	VREF		Internal Reference Voltage Out pin, 1.2V (Typ). A pull-down resistor is necessary externally. See "Notes on use."

Pin Descriptions (Continued)

NUMBER	SYMBOL	EQUIVALENT CIRCUIT	DESCRIPTION
26	NC		Vacant pin (no connection).
27	AV _{CC}		Analog V _{CC} .
28	NC		Vacant pin but connect to AV _{CC} (Note 1).
29	B _{OUT}		Analog Output pin for BLUE.
30	NC		Vacant pin but connect to AV _{CC} (Note 1).
31	G _{OUT}		Analog Output pin for GREEN.
32	NC		Vacant pin but connect to AV _{CC} (Note 1).
33	R _{OUT}		Analog Output pin for RED.
34 To 36	NC		Vacant pin but connect to AV _{CC} (Note 1).
19, 37, 43	DGND		Digital GND.
48	NC		Vacant pin (no connection).

NOTE:

1. Pins 30, 32, 34 and 36 are vacant, but in order to reduce interference between the individual RGB outputs, connect them to AV_{CC}.

HI1260

Absolute Maximum Ratings $T_A = 25^\circ\text{C}$

Supply Voltage, V_{CC}0V to 7V
Input Voltage (Digital) V_I	-0.3V to V_{CC}
V_{CLK}	-0.3V to V_{CC}
Input Voltage (V_{SET} Pin), V_{SET}	-0.3V to V_{CC}
Output Voltage (Analog), V_{OUT}	$V_{CC} - 2.1V$ to V_{CC}
Output Current (Analog), I_{OUT}	-3mA to 10mA
(V_{REF} Pin), I_{REF}	-5mA to 0mA
Allowable Power Dissipation, P_D	0.7W

Thermal Information

Thermal Resistance (Typical, Note 2)	θ_{JA} ($^\circ\text{C}/\text{W}$)
MQFP Package.....	85
Maximum Junction Temperature (Plastic Package).....	150 $^\circ\text{C}$
Maximum Storage Temperature Range.....	-55 $^\circ\text{C}$ to 150 $^\circ\text{C}$
Maximum Lead Temperature (Soldering 10s).....	300 $^\circ\text{C}$ (Lead Tips Only)

Recommended Operating Conditions

Temperature Range.....	-20 $^\circ\text{C}$ to 75 $^\circ\text{C}$
Supply Voltage	
AV_{CC} , DV_{CC}	4.5V to 5.5V
$AV_{CC} - DV_{CC}$	-0.2V to 0.2V
AGND - DGND.....	-0.05V to 0.05V
Digital Input Voltage	
H Level, V_{IH} , V_{CLKH}	2.0V to DV_{CC}
L Level, V_{IL} , V_{CLKL}	DGND to 0.8V

V_{SET} Input Voltage, V_{SET}	0.7V to 1.0V
V_{REF} Pin Current, I_{REF}	-3mA to 0.4mA
Clock Pulse Width	
t_{PW1}	15ns
t_{PW0}	10ns

CAUTION: Stresses above those listed in "Absolute Maximum Ratings" may cause permanent damage to the device. This is a stress only rating and operation of the device at these or any other conditions above those indicated in the operational sections of this specification is not implied.

NOTE:

- θ_{JA} is measured with the component mounted on an evaluation PC board in free air.

Electrical Specifications $T_A = 25^\circ\text{C}$, $AV_{CC} = DV_{CC} = 5.0V$, AGND = DGND = 0.0V

PARAMETER		SYMBOL	TEST CONDITIONS	NOTES	MIN	TYP	MAX	UNITS	
Resolution		RSL			-	8	-	Bit	
Monotony		MNT			-	Guarantee	-	-	
Differential Linearity Error		DLE	$V_{SET} - AGND = 0.87V$ $R_L > 10k\Omega$ $FS = \text{Full Scale}$		-0.5	-	0.5	LSB	
Integral Linearity Error		ILE			-0.4	-	4	% of FS	
Maximum Conversion Speed		f_{MAX}	$V_{SET} - AGND = 0.87V$ $R_L > 10k\Omega$ $C_L < 20pF$		35	-	-	MSPS	
Full Scale Output Voltage		V_{OFS}		Note 3	0.85	1.0	1.15	V_{P-P}	
RGB Output Voltage Full Scale Ratio		FSR		Note 4	0	4	8	%	
Output Zero Offset Voltage		V_{OFFSET}			-40	-6	0	mV	
Output Resistance		R_O			270	340	420	Ω	
Consumption Current		I_D	$V_{SET} - AGND = 0.87V$ $R_L > 10k\Omega$ $I_{REF} = -400\mu A$		54	72	90	mA	
Digital Data Input Current	H Level	Upper 2 Bits	$I_{IH(U)}$	$V_I = DV_{CC}$	-	1.2	20	μA	
		Lower 6 Bits	$I_{IH(L)}$		-	0.6	10	μA	
	L Level	Upper 2 Bits	$I_{IL(U)}$	$V_I = DGND$		-10	0	10	μA
		Lower 6 Bits	$I_{IL(L)}$			-10	0	10	μA
Clock Input Current	H Level	I_{CLKH}	$V_{CLK} = DV_{CC}$		-	3	30	μA	
	L Level	I_{CLKL}	$V_{CLK} = DGND$		-10	0	10	μA	
V_{SET} Input Current		I_{SET}	$V_{SET} = AGND = 0.87V$		-5	-0.3	0	μA	
Internal Reference Voltage		V_{REF}	$I_{REF} = -400\mu A$		1.08	1.20	1.32	V	
Set-Up Time		t_S			12	-	-	ns	
Hold Time		t_H			3	-	-	ns	

NOTES:

- $AV_{CC} - V_0$.
- Maximum value among $100 \times \left| \frac{V_{OFS(R)} - 1}{V_{OFS(G)}} \right|$, $100 \times \left| \frac{V_{OFS(G)} - 1}{V_{OFS(B)}} \right|$, or $100 \times \left| \frac{V_{OFS(B)} - 1}{V_{OFS(R)}} \right|$.

HI1260

TABLE 1. INPUT CORRESPONDING TABLE

INPUT CODE								OUTPUT VOLTAGE
MSB				LSB				
1	1	1	1	1	1	1	1	$V_{CC} + V_{OFFSET}$
				⋮				⋮
1	0	0	0	0	0	0	0	$V_{CC} + V_{OFFSET} - 0.5V$
				⋮				⋮
0	0	0	0	0	0	0	0	$V_{CC} + V_{OFFSET} - 1.0V$

Standard Circuit Design Data $T_A = 25^\circ C$, $AV_{CC} = DV_{CC} = 5.0V$, $AGND = DGND = 0.0V$

PARAMETER	SYMBOL	TEST CONDITIONS	NOTES	MIN	TYP	MAX	UNITS
Crosstalk Among R, G and B	CT	D/A OUT: 1Vp-p $R_L > 10k\Omega$ $C_L < 20pF$ $f_{DATA} = 7MHz$ $f_{CLK} = 14MHz$ See Figure 5		-	-40	-35	dB
Glitch Energy	GE	$V_{SET} - AGND = 0.87V$ $R_L > 10k\Omega$ $f_{CLK} = 1MHz$ Digital Ramp Output See Figure 6	Note 5	-	30	-	pV/s
Rise Time	t_r	$V_{SET} - AGND = 0.87V$ See Figure 4	Note 6	-	5.5	-	ns
Fall Time	t_f		Note 6	-	5.0	-	ns
Setting Time	t_{SET}		-	-	1.6	-	ns

NOTE:

5. Observe the glitch which is generated when the digital input varies as follows:

```

0 0 1 1 1 1 1 1 1 - 0 1 0 0 0 0 0 0 0
0 1 1 1 1 1 1 1 1 - 1 0 0 0 0 0 0 0 0
1 0 1 1 1 1 1 1 1 - 1 1 0 0 0 0 0 0 0
    
```

6. The time required for the D/A OUT to arrive at 90% of its final value from 10%.

Test Circuits and Waveforms

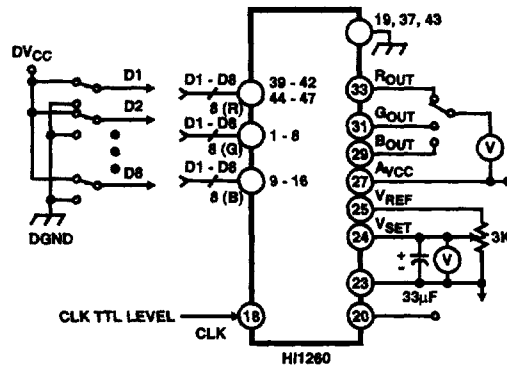

FIGURE 1. DIFFERENTIAL LINEARITY AND INTEGRAL LINEARITY TEST CIRCUIT

Test Circuits and Waveforms (Continued)

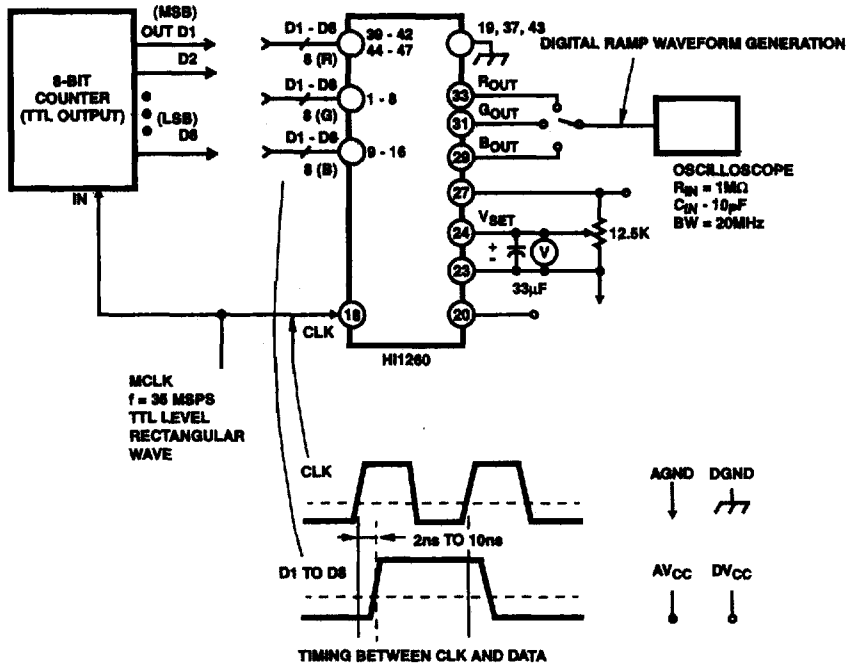

FIGURE 2. MAXIMUM CONVERSION RATE TEST CIRCUIT

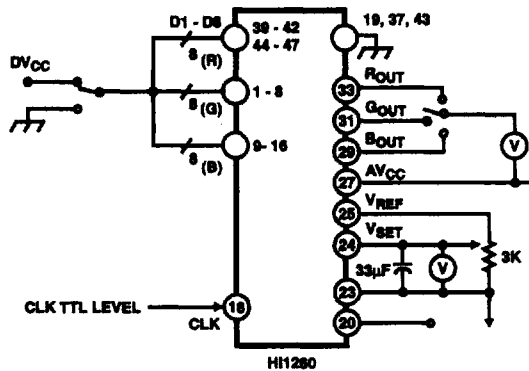

FIGURE 3. OUTPUT VOLTAGE FULL SCALE PRECISION, RGB OUTPUT VOLTAGE FULL SCALE RATIO, AND OUTPUT ZERO OFFSET VOLTAGE TEST CIRCUITS

Test Circuits and Waveforms (Continued)

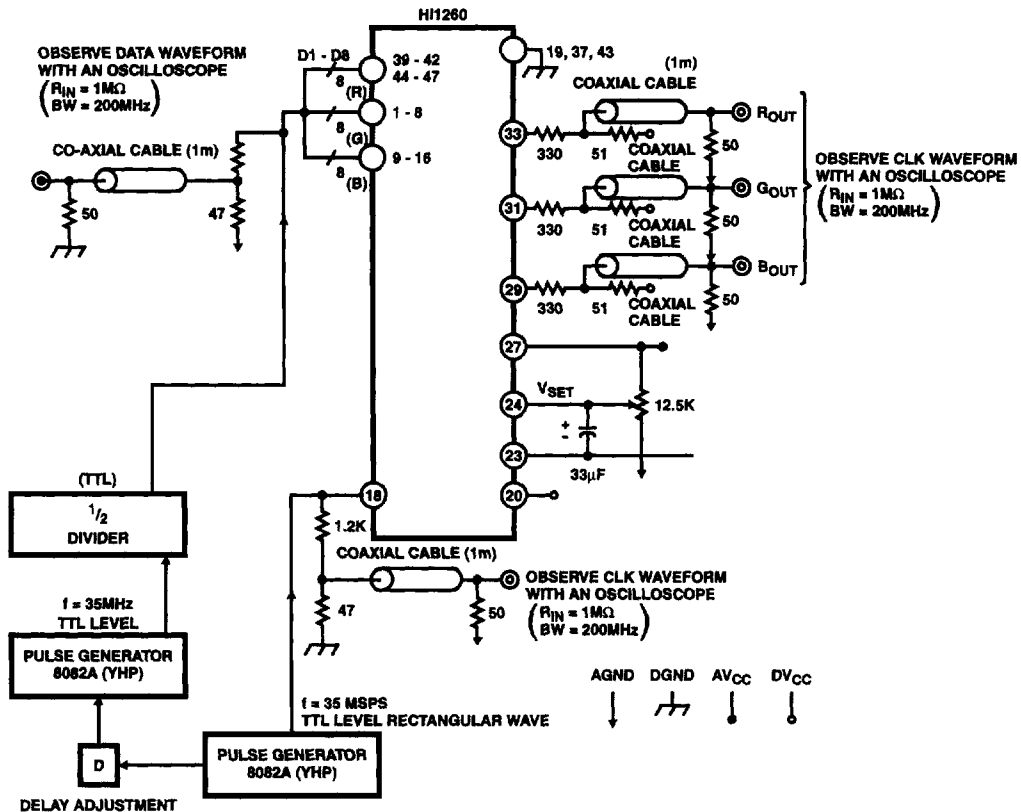
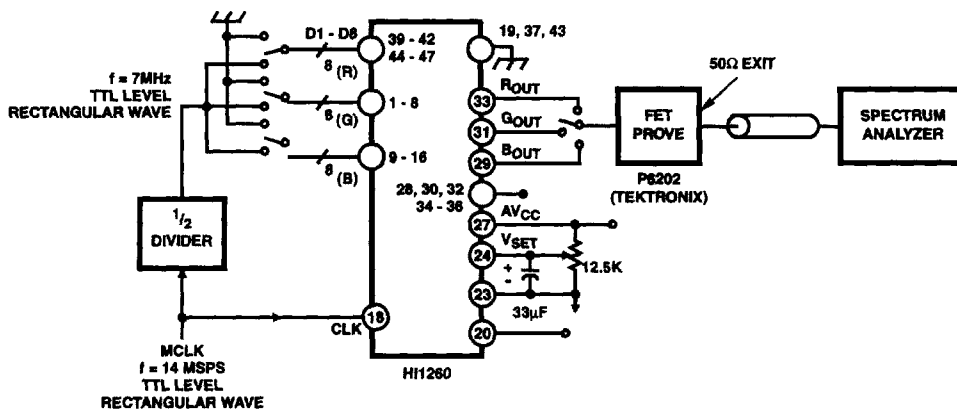

FIGURE 4. SETUP TIME, HOLD TIME, AND RISE AND FALL TIME TEST CIRCUITS



NOTES: The following notes cover the measurement methods in case the measuring crosstalk of G \rightarrow R:

7. Apply the data to G only and measure the power of the frequency component of the data at R_{OUT} .
8. Apply the data to R only and measure the power of the frequency component of the data at R_{OUT} .
9. Take the difference of the above two powers. The unit is in dB.

FIGURE 5. CROSSTALK AMONG R, G AND B TEST CIRCUIT

Test Circuits and Waveforms (Continued)

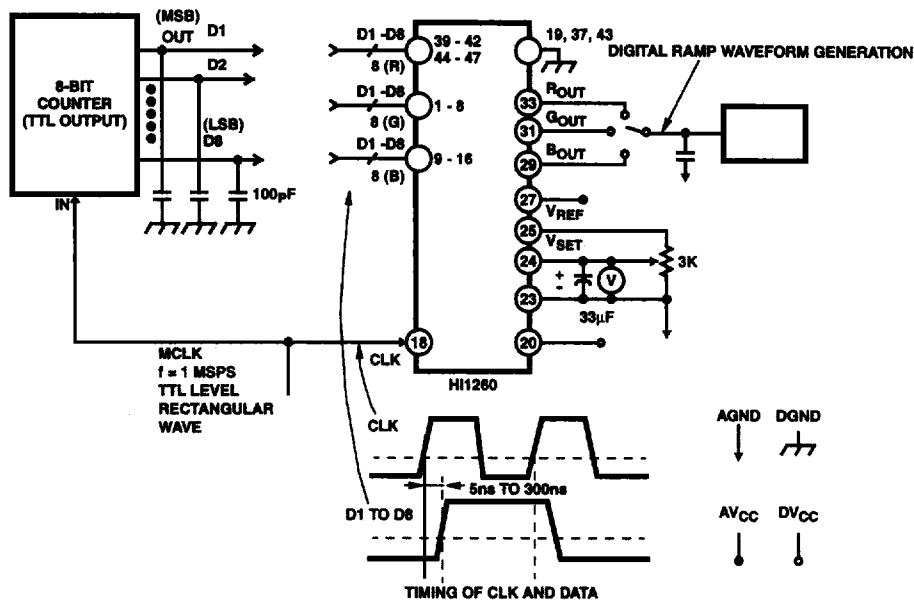
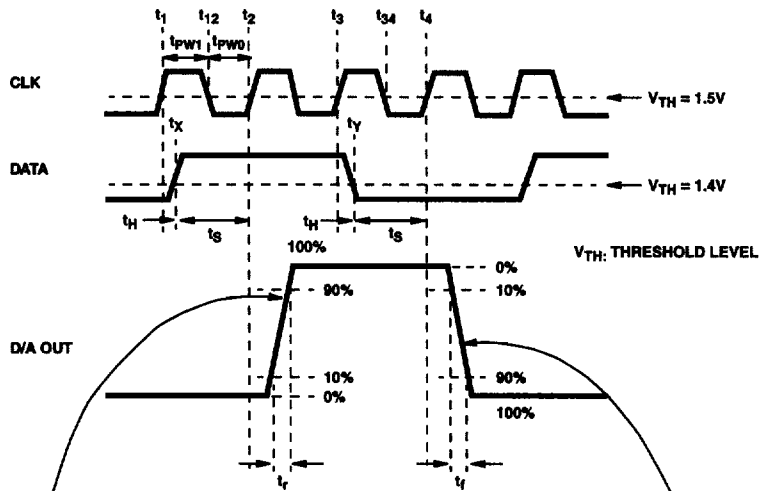

FIGURE 6. GLITCH ENERGY TEST CIRCUIT

Timing Diagram



At the time $t = t_x$, the data of individual bits are switched and thereafter, when the CLK becomes $L \rightarrow H$ at $t = t_2$, the D/A OUT is varied synchronous with it. That is, the D/A OUT is synchronous with the rise of the CLK. (In this case, fetching of the data is carried out at the fall of the CLK (at the time when $t = T_{12}$.)

At the time $t = T_y$, the data of individual bits are switched and thereafter, when the CLK becomes $L \rightarrow H$ at $t = t_4$, the D/A OUT is synchronous with it. That is, the D/A OUT is synchronous with the rise of the CLK. (In this case, fetching of the data is carried out at the fall of CLK (at the time when $t = t_4$.)

FIGURE 7.

Typical Performance Curves

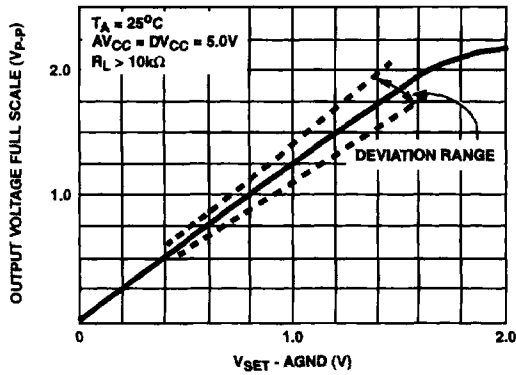

FIGURE 8. OUTPUT VOLTAGE FULL SCALE vs $V_{SET} - AGND$

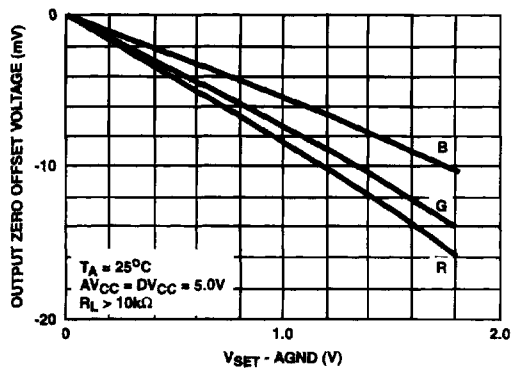

FIGURE 9. OUTPUT ZERO OFFSET VOLTAGE vs $V_{SET} - AGND$

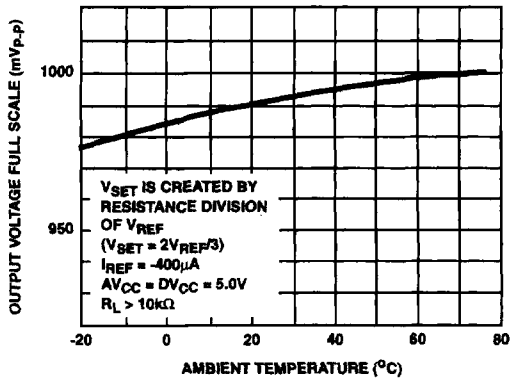

FIGURE 10. OUTPUT VOLTAGE FULL SCALE vs AMBIENT TEMPERATURE

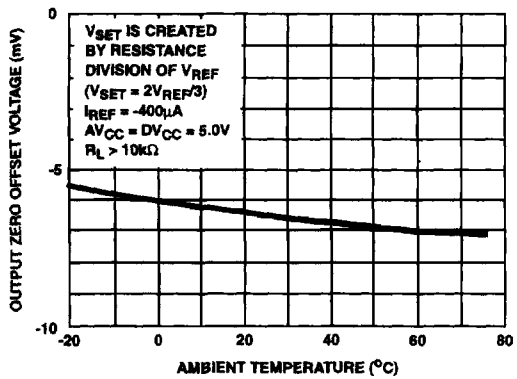

FIGURE 11. OUTPUT ZERO OFFSET VOLTAGE vs AMBIENT TEMPERATURE

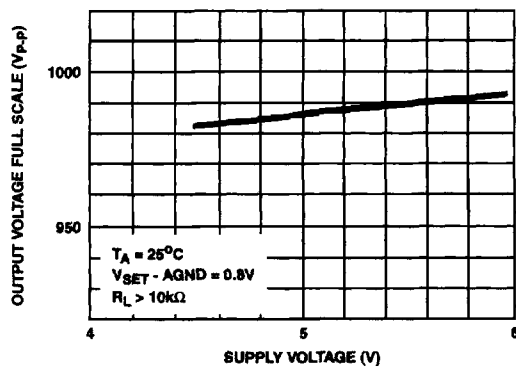

FIGURE 12. OUTPUT VOLTAGE FULL SCALE vs SUPPLY VOLTAGE

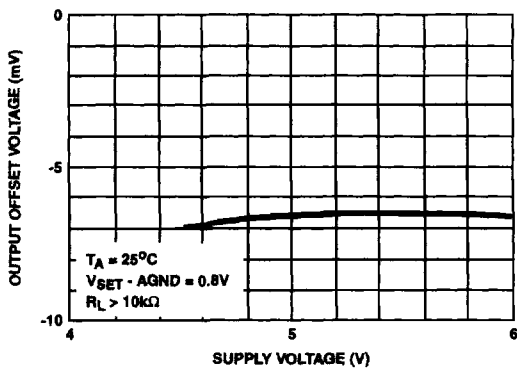

FIGURE 13. OUTPUT ZERO OFFSET VOLTAGE vs SUPPLY VOLTAGE

Typical Performance Curves (Continued)

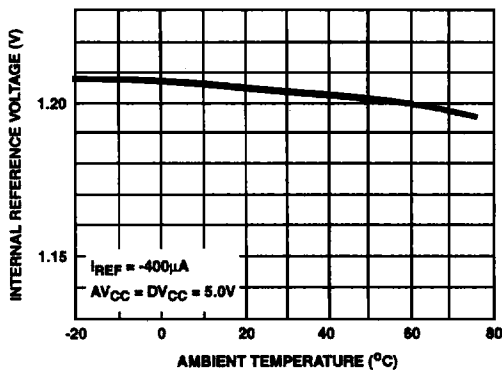

FIGURE 14. INTERNAL REFERENCE VOLTAGE vs AMBIENT TEMPERATURE

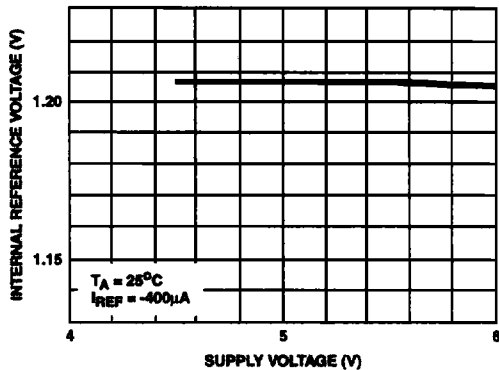

FIGURE 15. INTERNAL REFERENCE VOLTAGE vs SUPPLY VOLTAGE

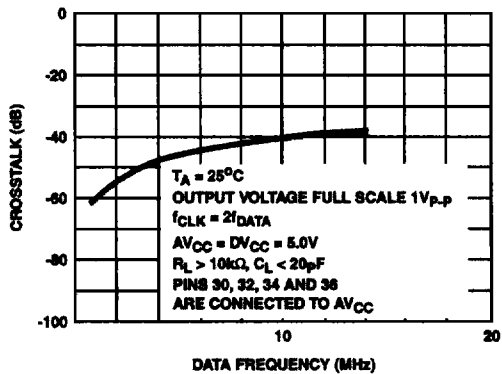

FIGURE 16. CROSSTALK AMONG R, G AND B vs DATA FREQUENCY

Typical Application Circuit

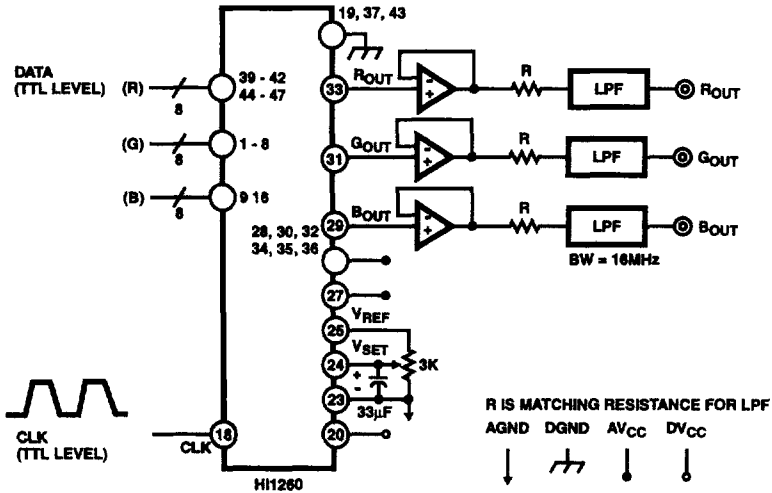

FIGURE 17.

Notes On Use

- **Setting of Pin 24 (VSET)**
The full scale of the D/A output voltage changes by applying voltage to pin 24 (VSET). When load is connected to pin 25 (VREF), DC voltage of 1.2V is issued and the said voltage is dropped to 0.87V by resistance division.
When the 0.87V is applied to pin 24 (VSET), the D/A output of 1V_{p-p} can be obtained.

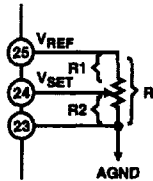

FIGURE 18. EXAMPLE OF USE

Adjustment Method

The resistance R is determined in accordance with the recommended operating condition of I_{REF} (Current flowing through resistance R).

See R vs I_{REF} of Figure 19. The calculation expression is as follows: $R = V_{REF}/I_{REF}$.

Adjust the volume so that the RGB output voltage full scale becomes 1.0V. (At this point, it becomes R1:R2 = 2:5).

• **Phase Relationship Between Data and Clock**

In order to obtain the desired characteristics as a D/A converter, it is necessary to set the phase relationship correctly between the externally applied data and clock.

- Satisfy the standard of the setup time (t_S) and hold time (t_H) indicated in the electrical characteristics. As to the reaming of t_S and t_H, see the timing chart.
Moreover, the clock pulse width is desired to be as indicated in the recommended operating condition.

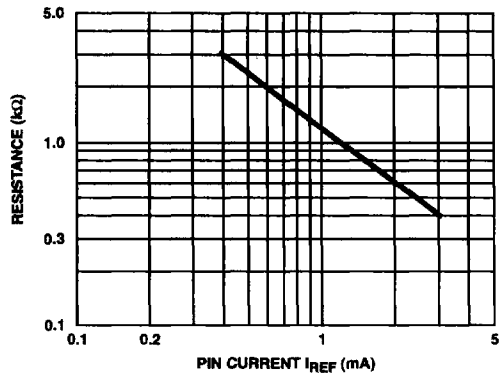

FIGURE 19. RESISTANCE vs V_{REF} PIN CURRENT

• **Regarding the Load of D/A Output Pin**

Receive the D/A output of the next stage with high impedance. In other words, perform so that it becomes as follows:

$R_L > 10k\Omega$
 $C_L < 20pF$

The temperature characteristics indicated in the characteristics diagram has been measured under this condition.

However, when it is made to $R_L \leq 10k\Omega$ the temperature characteristics may change considerably. In addition, when it is made to $C_L \leq 20pF$, the rise and fall of the D/A output become slow and will not operate at high speed.

• **Noise Reduction Measures**

As the D/A output voltage is a minute voltage of approximately 4mV per one step, ingenuity is required in reducing the noise entering from the outside of the IC as much as possible. Therefore, use the items given below as reference.

When mounting onto the printed board, allow as much space as possible to the ground surface and the V_{CC} surface on the board and reduce the parasitic inductance and resistance.

It is desirable that the AGND and DGND be separated in the pattern on the board. It is similar with AV_{CC} and DV_{CC} . As shown in the diagram below, for example, it is

recommended that the wiring to the electric supply of AGND and DGND as also AV_{CC} and DV_{CC} be conducted separately, and then making AGND and DGND as also AV_{CC} and DV_{CC} in common right near the power supply respectively.

Inset in parallel a 47 μF tantalum capacitor and a 100pF ceramic capacitor between the V_{CC} surface on the printed board and the nearest ground surface (A of diagram below). It is also desirable to insert the above between the V_{CC} surface near the pin of the IC and the ground surface (B of diagram below). They are bypass capacitors to prevent bad effects from occurring to the characteristics when the power supply voltage fluctuates due to the clock, etc.

It is recommended to reduce noise which overlaps the D/A output by inserting a capacitor of over 0.1 μF between pin 23 (AGND) and pin 24 (V_{SET}).

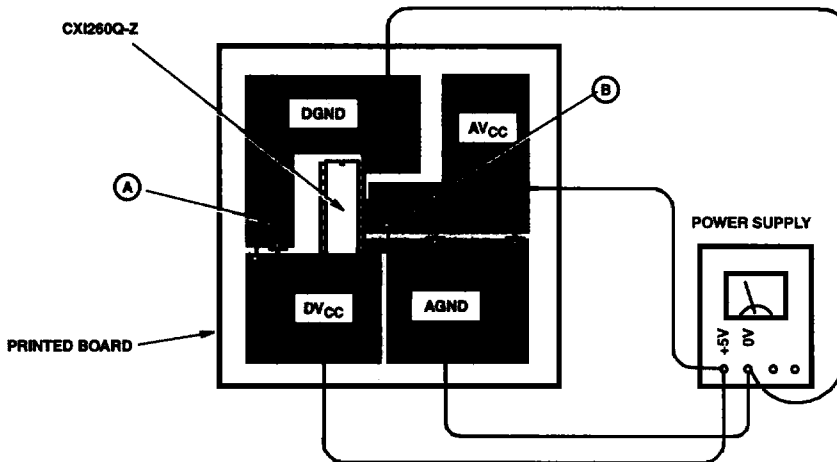

FIGURE 20.