



# TDA7464

## DIGITALLY CONTROLLED AUDIO PROCESSOR WITH SRS SURROUND SOUND AND VOICE CANCELLER



everything else is only stereo™

The Device incorporates the SRS WOW® Technology under licence from SRS Labs, Inc.

- 4 STEREO INPUTS
- INPUT ATTENUATION CONTROL IN 0.5dB STEP
- TREBLE MIDDLE AND BASS CONTROL
- VOICE CANCELLER IS AVAILABLE
- STEREO SRS SURROUND SOUND WITH CENTER & SPACE CONTROL IS AVAILABLE
- THREE STANDARD SURROUND MODES ARE AVAILABLE:
  - MUSIC IN 4 DIFFERENT SELECTABLE RESPONSES
  - MOVIE AND SIMULATED IN 256 DIFFERENT SELECTABLE RESPONSES
- 2 SPEAKERS OUTPUTS
  - INDEPENDENT ATTENUATORS IN 1dB STEP FOR BALANCE FACILITY
  - ZERO CROSSING ATTENUATION AVAILABLE
  - INDEPENDENT MUTE FUNCTION
- 2 RECORD OUTPUTS
  - INDEPENDENT ATTENUATORS IN 1dB STEP FOR BALANCE FACILITY
  - MUX AVAILABLE FOR PROCESSES SIGNAL SELECTION
  - INDEPENDENT MUTE FUNCTION
- ALL FUNCTIONS PROGRAMMABLE VIA SERIAL BUS

### DESCRIPTION

The TDA7464 is a volume tone (bass middle and treble) balance (Left/Right) processors with stereo SRS and voice canceller for quality audio applications in car radio, Hi-Fi, TV systems. It reproduces SRS (Sound Retrieval System) sound by external components and surround sound by using phase shifters and a signal matrix. The AC signal setting is obtained by resistor networks and switches combined with operational amplifiers according to the SRS laboratories

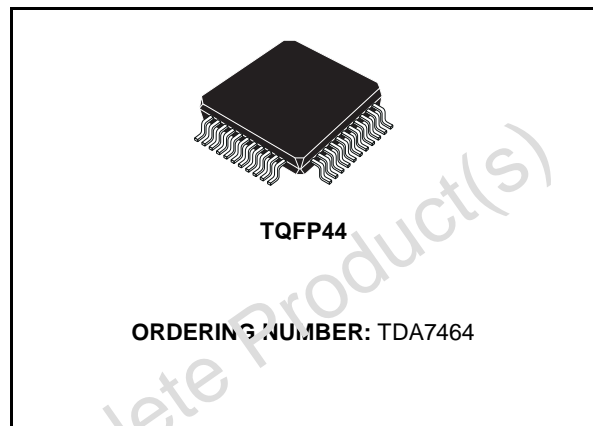

### PIN CONNECTION

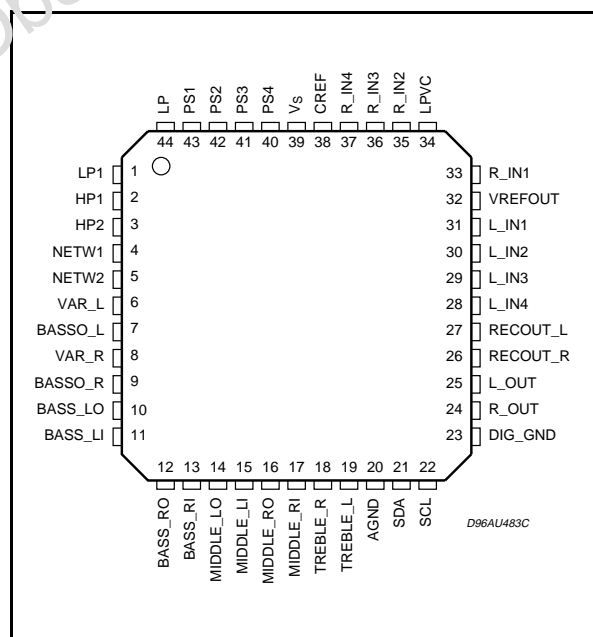

specification. Control of all the functions is accomplished by serial bus. Thanks to the used BIPOLAR/CMOS Technology, Low Distortion, Low Noise and DC stepping are obtained.

BLOCK DIAGRAM

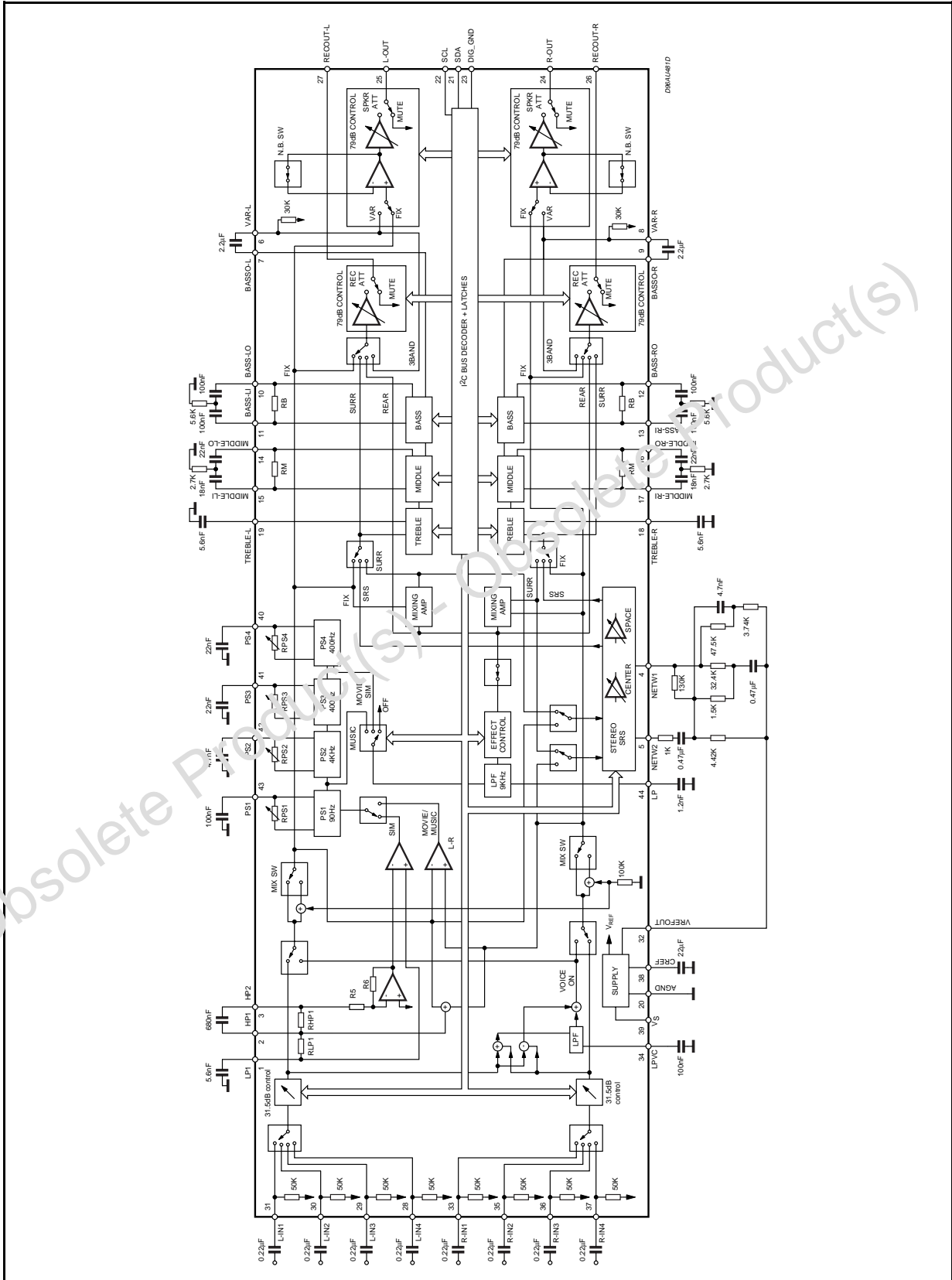

## THERMAL DATA

Symbol	Description	Value	Unit
$R_{th\ j-pins}$	Thermal Resistance Junction-pins	Max.	85 °C/W

## ABSOLUTE MAXIMUM RATINGS

Symbol	Parameter	Value	Unit
$V_S$	Operating Supply Voltage	11	V
$T_{amb}$	Operating Ambient Temperature	-10 to 85	°C
$T_{stg}$	Storage Temperature Range	-55 to +150	°C

## QUICK REFERENCE DATA

Symbol	Parameter	Min.	Typ.	Max.	Unit
$V_S$	Supply Voltage	7	9	10.2	V
$V_{CL}$	Max. input signal handling	2			Vrms
THD	Total Harmonic Distortion $V = 1V_{rms}$ $f = 1KHz$		0.01	0.1	%
S/N	Signal to Noise Ratio $V_{out} = 1V_{rms}$ (mode = OFF)		106		dB
$S_C$	Channel Separation $f = 1KHz$		90		dB
	Input Attenuation Control (0.5dB)	-31.5		0	dB
	Treble Control (2db step)	-14		+14	dB
	Middle Control (2db step)	-14		+14	dB
	Bass Control (2dB step)	-14		+14	dB
	Balance Control 1dB step (LCH, RCH)	-79		0	dB
	Mute Attenuation		100		dB

**ELECTRICAL CHARACTERISTICS** (refer to the test circuit  $T_{amb} = 25^{\circ}C$ ,  $V_S = 9V$ ,  $R_L = 10K\Omega$ ,  $V_{in} = 1V_{rms}$ ;  $R_G = 600\Omega$ , all controls flat ( $G = 0dB$ ), Effect Ctrl = -6dB, MODE = OFF;  $f = 1KHz$  unless otherwise specified)

Symbol	Parameter	Test Condition	Min.	Typ.	Max.	Unit
--------	-----------	----------------	------	------	------	------

## SUPPLY

$V_S$	Supply Voltage		7	9	10.2	V
$I_S$	Supply Current			25		mA
SVR	Ripple Rejection	LCH / RCH out, Mode = OFF	60	80		dB

## INPUT STAGE

$R_{IN}$	Input Resistance		37.5	50	62.5	K $\Omega$
$V_{CL}$	Clipping Level	THD = 0.3%	2	2.5		Vrms
$A_{RANGE}$	Attenuation Range			31.5		dB
$A_{VMIN}$	Min. Attenuation		-1	0	1	dB
$A_{VMAX}$	Max. Attenuation		31	31.5	32	dB
$A_{STEP}$	Step Resolution		-1	0.5	1	dB
$V_{DC}$	DC Steps	Adjacent att. step	-3	0	3	mV
$A_{VO1}$	Voice Canceller Output 1	$L_{IN} = R_{IN}$ , $R_{IN} = ON$ , $V_{mix} = 0V_{FIX}$ , 0dB attenuation	5	6	7	dB
$A_{VO2}$	Voice Canceller Output 2	$L_{IN} = R_{IN} = 0V$ $V_{mix} = 1V_{rms}$ FIX, 0dB attenuation	-1	0	1	dB

## ELECTRICAL CHARACTERISTICS (continued)

Symbol	Parameter	Test Condition	Min.	Typ.	Max.	Unit
<b>SUPPLY</b>						
A <sub>VO3</sub>	Voice Canceller Output 3	L <sub>IN</sub> = -R <sub>IN</sub> , V <sub>mix</sub> = 0V FIX, 0dB attenuation	5	6	7	dB
R <sub>LPV</sub>	Low Pass Filter Resistance		24	32	40	KΩ
<b>BASS CONTROL</b>						
G <sub>b</sub>	Control Range	Max. Boost/cut	±12.0	±14.0	±16.0	dB
B <sub>STEP</sub>	Step Resolution		1	2	3	dB
R <sub>B</sub>	Internal Feedback Resistance		33	44	55	KΩ
<b>MIDDLE CONTROL</b>						
G <sub>m</sub>	Control Range	Max. Boost/cut	±12.0	±14.0	±16.0	dB
M <sub>STEP</sub>	Step Resolution		1	2	3	dB
R <sub>M</sub>	Internal Feedback Resistance		18.75	25	31.25	KΩ
<b>TREBLE CONTROL</b>						
G <sub>t</sub>	Control Range	Max. Boost/cut	±13.0	±14.0	±15.0	dB
T <sub>STEP</sub>	Step Resolution		1	2	3	dB

## STANDARD SURROUND SOUND MATRIX

TEST CONDITION (Phase Resistor Selection D0=0, D1=1, D2=0, D3=1, D4=0, D5=1, D6=0, D7=1)

Symbol	Parameter	Test Condition	Min.	Typ.	Max.	Unit
G <sub>OFF</sub>	In-phase Gain (OFF)	Mode OFF, Input signal of 1kHz, 1.4 V <sub>p-p</sub> , R <sub>in</sub> → R <sub>out</sub> L <sub>in</sub> → L <sub>out</sub>	-1	0	1	dB
D <sub>G<sub>OFF</sub></sub>	LR In-phase Gain Difference (OFF)	Mode OFF, Input signal of 1kHz, 1.4 V <sub>p-p</sub> R <sub>in</sub> → R <sub>out</sub> , L <sub>in</sub> → L <sub>out</sub>	-1	0	1	dB
G <sub>MOV</sub>	In-phase Gain (Movie)	Movie mode, Effect Ctrl = -6dB Input signal of 1kHz, 1.4 V <sub>p-p</sub> R <sub>in</sub> → R <sub>out</sub> , L <sub>in</sub> → L <sub>out</sub>		8		dB
D <sub>G<sub>MOV</sub></sub>	LR In-phase Gain Difference (Movie)	Movie mode, Effect Ctrl = -6dB Input signal of 1kHz, 1.4 V <sub>p-p</sub> (R <sub>in</sub> → R <sub>out</sub> ) - (L <sub>in</sub> → L <sub>out</sub> )		0		dB
G <sub>MUS</sub>	In-phase Gain (Music)	Music mode, Effect Ctrl = -6dB Input signal of 1kHz, 1.4 V <sub>p-p</sub> (R <sub>in</sub> → R <sub>out</sub> ), (L <sub>in</sub> → L <sub>out</sub> )		7		dB
D <sub>G<sub>MUS</sub></sub>	LR In-phase Gain Difference (Music)	Music mode, Effect Ctrl = -6dB Input signal of 1kHz, 1.4 V <sub>p-p</sub> (R <sub>in</sub> → R <sub>out</sub> ) - (L <sub>in</sub> → L <sub>out</sub> )		0		dB
L <sub>MON1</sub>	Simulated L Output 1	Simulated Mode, Effect Ctrl = -6dB Input signal of 250Hz, 1.4 V <sub>p-p</sub> , R <sub>in</sub> and L <sub>in</sub> → L <sub>out</sub>		4.5		dB
L <sub>MON2</sub>	Simulated L Output 2	Simulated Mode, Effect Ctrl = -6dB Input signal of 1kHz, 1.4 V <sub>p-p</sub> , R <sub>in</sub> and L <sub>in</sub> → L <sub>out</sub>		-4.0		dB
L <sub>MON3</sub>	Simulated L Output 3	Simulated Mode, Effect Ctrl = -6dB Input signal of 3.6kHz, 1.4 V <sub>p-p</sub> , R <sub>in</sub> and L <sub>in</sub> → L <sub>out</sub>		7.0		dB

## ELECTRICAL CHARACTERISTICS (continued)

Symbol	Parameter	Test Condition	Min.	Typ.	Max.	Unit
R <sub>MON1</sub>	Simulated R Output 1	Simulated Mode, Effect Ctrl = -6dB Input signal of 250Hz, 1.4 V <sub>p-p</sub> , R <sub>in</sub> and L <sub>in</sub> → R <sub>out</sub>		- 4.5		dB
R <sub>MON2</sub>	Simulated R Output 2	Simulated Mode, Effect Ctrl = -6dB Input signal of 1kHz, 1.4 V <sub>p-p</sub> , R <sub>in</sub> and L <sub>in</sub> → R <sub>out</sub>		3.8		dB
R <sub>MON3</sub>	Simulated R Output 3	Simulated Mode, Effect Ctrl = -6dB Input signal of 3.6kHz, 1.4 V <sub>p-p</sub> , R <sub>in</sub> and L <sub>in</sub> → R <sub>out</sub>		- 20		dB
R <sub>LP1</sub>	Low Pass Filter Resistance		7.5	10	12.5	KΩ
R <sub>HPI</sub>	High Pass Filter Resistance		45	60	75	KΩ
R <sub>LPF</sub>	LP Pin Impedance		7.5	10	12.5	KΩ

## STANDARD SURROUND SOUND EFFECT CONTROL

C <sub>RANGE</sub>	Control Range		- 21		- 6	dB
S <sub>STEP</sub>	Step Resolution			1		dB

## SURROUND SOUND MATRIX PHASE

R <sub>PS10</sub>	Phase Shifter 1: D1 = 0, D0 = 0		9.8	11.8	14.8	KΩ
R <sub>PS11</sub>	Phase Shifter 1: D1 = 0, D0 = 1		10.6	14.1	17.6	KΩ
R <sub>PS12</sub>	Phase Shifter 1: D1 = 1, D0 = 0		13.4	17.9	22.4	KΩ
R <sub>PS13</sub>	Phase Shifter 1: D1 = 1, D0 = 1		28	37.3	46.6	KΩ
R <sub>PS20</sub>	Phase Shifter 2: D3 = 0, D2 = 0		4.2	5.6	7	KΩ
R <sub>PS21</sub>	Phase Shifter 2: D3 = 0, D2 = 1		5.1	6.8	8.5	KΩ
R <sub>PS22</sub>	Phase Shifter 2: D3 = 1, D2 = 0		6.3	8.4	10.5	KΩ
R <sub>PS23</sub>	Phase Shifter 2: D3 = 1, D2 = 1		13.7	18.3	22.9	KΩ
R <sub>PS30</sub>	Phase Shifter 3: D5 = 0, D4 = 0		9	12.1	15.1	KΩ
R <sub>PS31</sub>	Phase Shifter 3: D5 = 0, D4 = 1		10.9	14.5	18.1	KΩ
R <sub>PS32</sub>	Phase Shifter 3: D5 = 1, D4 = 0		13.6	18.1	22.6	KΩ
R <sub>PS33</sub>	Phase Shifter 3: D5 = 1, D4 = 1		29.3	39.1	48.9	KΩ
R <sub>PS40</sub>	Phase Shifter 4: D7 = 0, D6 = 0		9	12.1	15.1	KΩ
R <sub>PS41</sub>	Phase Shifter 4: D7 = 0, D6 = 1		10.9	14.5	18.1	KΩ
R <sub>PS42</sub>	Phase Shifter 4: D7 = 1, D6 = 0		13.6	18.1	22.6	KΩ
R <sub>PS43</sub>	Phase Shifter 4: D7 = 1, D6 = 1		29.3	39.1	48.9	KΩ

## SRS SURROUND SOUND MATRIX

C <sub>CENTER</sub>	SRS Control Range		-31		0	dB
Step <sub>C</sub>	Center Step Resolution			1		dB
SPACE	SRS Space Control Range			-31	0	dB
Steps	Space Step Resolution			1		dB
P <sub>ERSP1</sub>	Perspective 1	Input Signal of 125Hz SPACE = 0dB, CENTER = MUTE R <sub>in</sub> = GND; L <sub>in</sub> → R <sub>OUT</sub>		12		dB
P <sub>ERSP2</sub>	Perspective 2	Input Signal of 2.15KHz SPACE = 0dB, CENTER = MUTE R <sub>in</sub> = GND; L <sub>in</sub> → R <sub>OUT</sub>		0		dB
L+R	L+ R SRS Curve	SPACE = MUTE, CENTER = 0dB R <sub>in</sub> = GND; L <sub>in</sub> → R <sub>OUT</sub>		-8.5		dB
L, R	L, R SRS Curve	SPACE = MUTE, CENTER = MUTE R <sub>in</sub> = GND; L <sub>in</sub> → L <sub>OUT</sub> L <sub>in</sub> = GND; R <sub>in</sub> → R <sub>OUT</sub>		-13.4		dB

## ELECTRICAL CHARACTERISTICS (continued)

Symbol	Parameter	Test Condition	Min.	Typ.	Max.	Unit
<b>SPEAKER &amp; RECORD ATTENUATORS</b>						
C <sub>range</sub>	Control Range			79		dB
S <sub>STEP</sub>	Step Resolution		0.5	1	1.5	dB
E <sub>A</sub>	Attenuation set error	Av = 0 to -20dB	-1.5	0	1.5	dB
		Av = -20 to -79dB	-3	0	2	dB
V <sub>DC</sub>	DC Steps	Adjacent att. steps	-3	0	3	mV
A <sub>MUTE</sub>	Output Mute Condition		70	100		dB
R <sub>VAR</sub>	Input Impedance		22.5	30	37.5	KΩ
<b>SPEAKER ATTENUATORS</b>						
V <sub>TH</sub>	Zero Crossing Threshold	D7 = 0		$\frac{V_S}{2} + 20$		mV
<b>AUDIO OUTPUTS</b>						
N <sub>O(OFF)</sub>	Output Noise (OFF)	Output Mute, Flat B <sub>W</sub> = 20Hz to 20KHz		4 5		μVrms μVrms
N <sub>O(MOV)</sub>	Output Noise (Movie) Standard Surround Sound	Mode = Movie , B <sub>W</sub> = 20Hz to 20KHz		30		μVrms
N <sub>O(MUS)</sub>	Output Noise (Music) Standard Surround Sound	Mode = Music , B <sub>W</sub> = 20Hz to 20KHz		30		μVrms
N <sub>O(SIM)</sub>	Output Noise (Simulated) Standard Surround Sound	Mode = Simulated, B <sub>W</sub> = 20Hz to 20KHz		30		μVrms
N <sub>O(SRS)</sub>	Output Noise (SRS) Surround Sound	B <sub>W</sub> = 20Hz to 20KHz		50		μVrms
d	Distorsion	A <sub>v</sub> = 0 ; V <sub>in</sub> = 1Vrms		0.01	0.1	%
S <sub>C</sub>	Channel Separation		70	90		dB
V <sub>OCL</sub>	Clipping Level	d = 0.3%	2	2.5		Vrms
R <sub>OUT</sub>	Output Resistance		10	30	50	Ω
V <sub>OUT</sub>	DC Voltage Level			3.8		V
<b>BUS INPUTS</b>						
V <sub>IL</sub>	Input Low Voltage				1	V
V <sub>IH</sub>	Input High Voltage		3			V
I <sub>IN</sub>	Input Current		-5		+5	μA
V <sub>IO</sub>	Output Voltage SDA Acknowledge	I <sub>o</sub> = 1.6mA			0.4	V

**I<sup>2</sup>C BUS INTERFACE**

Data transmission from microprocessor to the TDA7464, and viceversa takes place through the 2 wires I<sup>2</sup>C BUS interface, consisting of the two lines SDA and SCL (pull-up resistors to positive supply voltage must be connected).

**Data Validity**

As shown in fig. 3, the data on the SDA line must be stable during the high period of the clock. The HIGH and LOW state of the data line can only change when the clock signal on the SCL line is LOW.

**Start and Stop Conditions**

As shown in fig.4 a start condition is a HIGH to LOW transition of the SDA line while SCL is HIGH. The stop condition is a LOW to HIGH transition of the SDA line while SCL is HIGH.

**Byte Format**

Every byte transferred on the SDA line must contain 8 bits. Each byte must be followed by an ac-

knowledge bit. The MSB is transferred first.

**Acknowledge**

The master (μP) puts a resistive HIGH level on the SDA line during the acknowledge clock pulse (see fig. 5). The peripheral (audioprocessor) that acknowledges has to pull-down (LOW) the SDA line during this clock pulse.

The audioprocessor which has been addressed has to generate an acknowledge after the reception of each byte, otherwise the SDA line remains at the HIGH level during the ninth clock pulse time. In this case the master transmitter can generate the STOP information in order to abort the transfer.

**Transmission without Acknowledge**

Avoiding to detect the acknowledge of the audioprocessor, the μP can use a simpler transmission: simply it waits one clock without checking the slave acknowledging, and sends the new data.

This approach of course is less protected from misworking.

**Figure 3:** Data Validity on the I<sup>2</sup>CBUS

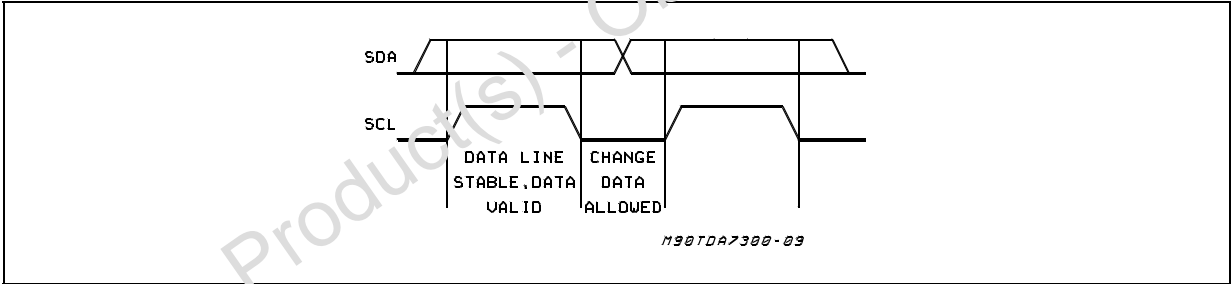

**Figure 4:** Timing Diagram of I<sup>2</sup>CBUS

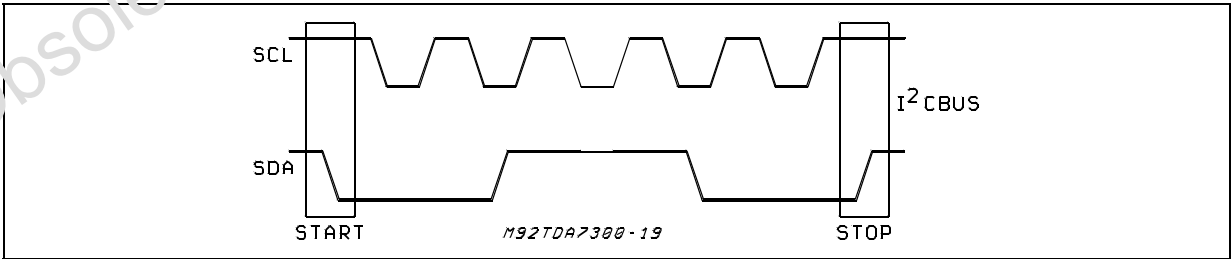

**Figure 5:** Acknowledge on the I<sup>2</sup>CBUS

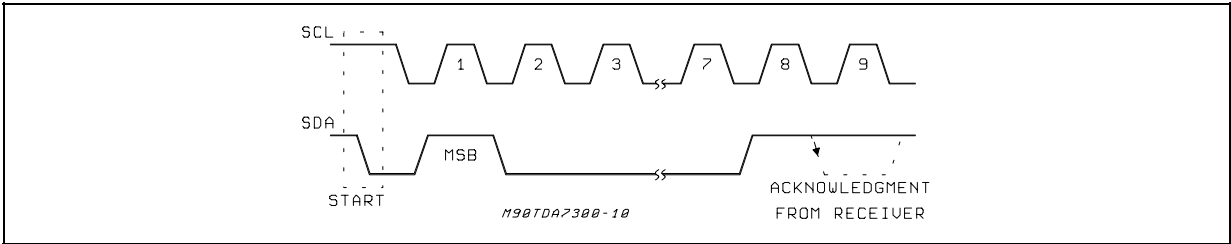

# TDA7464

## SOFTWARE SPECIFICATION

Interface Protocol

The interface protocol comprises:

- A start condition (S)
- A chip address byte, containing the TDA7464

address

- A subaddress bytes
- A sequence of data (N byte + acknowledge)
- A stop condition (P)

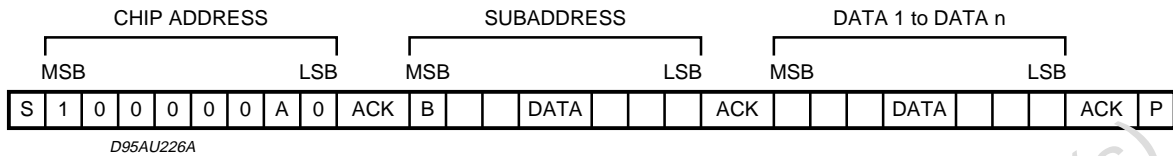

ACK = Acknowledge  
 S = Start  
 P = Stop  
 A = Address  
 B = Auto Increment

## EXAMPLES

### No Incremental Bus

The TDA7464 receives a start condition, the cor-

rect chip address, a subaddress with the MSB = 0 (no incremental bus), N-data (all these data concern the subaddress selected), a stop condition.

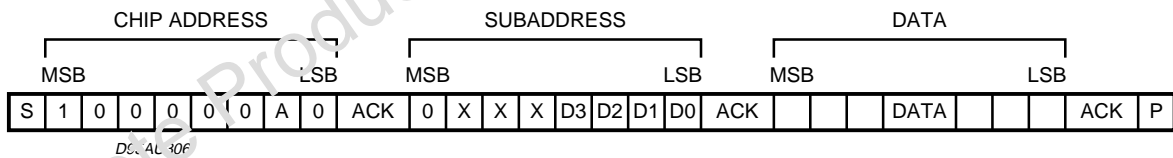

### Incremental Bus

The TDA7464 receives a start condition, the correct chip address, a subaddress with the MSB = 1 (incremental bus): now it is in a loop condition with an autoincrease of the subaddress whereas

SUBADDRESS from "1XXX1010" to "1XXX1111" of DATA are ignored.

The DATA 1 concerns the subaddress sent, and the DATA 2 concerns the subaddress sent plus one in the loop etc. and, at the end, it receives the stop condition.

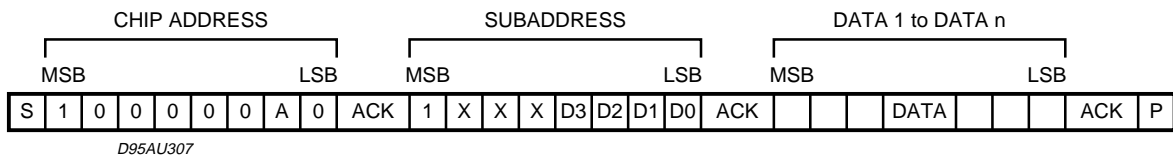



**DATA BYTES** (Address = 80(HEX)):

**FUNCTION SELECTION:**

The first byte (subaddress)

MSB							LSB		SUBADDRESS
D7	D6	D5	D4	D3	D2	D1	D0		
B	X	X	X	0	0	0	0	INPUT ATTENUATION	
B	X	X	X	0	0	0	1	SURROUND & OUT & EFFECT CONTROL	
B	X	X	X	0	0	1	0	PHASE RESISTOR	
B	X	X	X	0	0	1	1	BASS	
B	X	X	X	0	1	0	0	MIDDLE & TREBLE	
B	X	X	X	0	1	0	1	SPEAKER ATTENUATION "L"	
B	X	X	X	0	1	1	0	SPEAKER ATTENUATION "R"	
B	X	X	X	0	1	1	1	RECORD ATTENUATION "L"	
B	X	X	X	1	0	0	0	RECORD ATTENUATION "R"	
B	X	X	X	1	0	0	1	INPUT MULTIPLEXER, VOICE CANCELLER & REC OUT	
B	X	X	X	1	0	1	0	SRS / SPACE ATTENUATION	
B	X	X	X	1	0	1	1	SRS / CENTER ATTENUATION	

B = 1 INCREMENTAL BUS; ACTIVE

B = 0 NO INCREMENTAL BUS;

X = DON'T CARE

**INPUT ATTENUATION SELECTION**

MSB							LSB		INPUT ATTENUATION
D7	D6	D5	D4	D3	D2	D1	D0	0.5 dB STEPS	
	1				0	0	0	0	
	1				0	0	1	-0.5	
	1				0	1	0	-1	
	1				0	1	1	-1.5	
	1				1	0	0	-2	
	1				1	0	1	-2.5	
	1				1	1	0	-3	
	1				1	1	1	-3.5	
<b>4 dB STEPS</b>									
	1	0	0	0				0	
	1	0	0	1				-4	
	1	0	1	0				-8	
	1	0	1	1				-12	
	1	1	0	0				-16	
	1	1	0	1				-20	
	1	1	1	0				-24	
	1	1	1	1				-28	

INPUT ATTENUATION = 0 ~ -31.5dB

## STANDARD SURROUND SELECTION

MSB							LSB		
D7	D6	D5	D4	D3	D2	D1	D0	SURROUND MODE	
						0	0	SIMULATED	
						0	1	MUSIC	
						1	0	OFF	
						1	1	MOVIE	
								<b>OUT</b>	
								VAR	
								FIX	
								<b>EFFECT CONTROL</b>	
	0	0	0	0				-6	
	0	0	0	1				-7	
	0	0	1	0				-8	
	0	0	1	1				-9	
	0	1	0	0				-10	
	0	1	0	1				-11	
	0	1	1	0				-12	
	0	1	1	1				-13	
	1	0	0	0				-14	
	1	0	0	1				-15	
	1	0	1	0				-16	
	1	0	1	1				-17	
	1	1	0	0				-18	
	1	1	0	1				-19	
	1	1	1	0				-20	
	1	1	1	1				-21	
<b>PHASE RESISTOR SELECTION</b>									
MSB							LSB		SURROUND PHASE RESISTOR
D7	D6	D5	D4	D3	D2	D1	D0	PHASE SHIFT 1 (K $\Omega$ )	
						0	0	12	
						0	1	14	
						1	0	18	
						1	1	37	
								<b>PHASE SHIFT 2 (K<math>\Omega</math>)</b>	
								6	
								7	
								8	
								18	
								<b>PHASE SHIFT 3 (K<math>\Omega</math>)</b>	
								12	
								14	
								18	
								39	
								<b>PHASE SHIFT 4 (K<math>\Omega</math>)</b>	
0	0							12	
0	1							14	
1	0							18	
1	1							39	

BASS SELECTION									
MSB							LSB	BASS	
D7	D6	D5	D4	D3	D2	D1	D0	2 dB STEPS	
			1	0	0	0	0	-14	
			1	0	0	0	1	-12	
			1	0	0	1	0	-10	
			1	0	0	1	1	-8	
			1	0	1	0	0	-6	
			1	0	1	0	1	-4	
			1	0	1	1	0	-2	
			1	0	1	1	1	0	
			1	1	1	1	1	0	
			1	1	1	1	0	2	
			1	1	1	0	1	4	
			1	1	1	0	0	6	
			1	1	0	1	1	8	
			1	1	0	1	0	10	
			1	1	0	0	1	12	
			1	1	0	0	0	14	

Obsolete Product(s) - Obsolete Product(s)

MIDDLE & TREBLE SELECTION									
MSB							LSB	MIDDLE	
D7	D6	D5	D4	D3	D2	D1	D0	2 dB STEPS	
				0	0	0	0	-14	
				0	0	0	1	-12	
				0	0	1	0	-10	
				0	0	1	1	-8	
				0	1	0	0	-6	
				0	1	0	1	-4	
				0	1	1	0	-2	
				0	1	1	1	0	
				1	1	1	1	0	
				1	1	1	0	2	
				1	1	0	1	4	
				1	1	0	0	6	
				1	0	1	1	8	
				1	0	1	0	10	
				1	0	0	1	12	
				1	0	0	0	14	
								<b>TREBLE</b>	
								<b>2 dB STEPS</b>	
0	0	0	0					-14	
0	0	0	1					-12	
0	0	1	0					-10	
0	0	1	1					-8	
0	1	0	0					-6	
0	1	0	1					-4	
0	1	1	0					-2	
0	1	1	1					0	
1	1	1	1					0	
1	1	1	0					2	
1	1	0	1					4	
1	1	0	0					6	
1	0	1	1					8	
1	0	1	0					10	
1	0	0	1					12	
1	0	0	0					14	

LEFT CHANNEL SPEAKER ATTENUATION SELECTION								
MSB							LSB	SPEAKER/RECORD ATT
D7	D6	D5	D4	D3	D2	D1	D0	1 dB STEPS
					0	0	0	0
					0	0	1	-1
					0	1	0	-2
					0	1	1	-3
					1	0	0	-4
					1	0	1	-5
					1	1	0	-6
					1	1	1	-7
								8 dB STEPS
	0	0	0	0				0
	0	0	0	1				-8
	0	0	1	0				-16
	0	0	1	1				-24
	0	1	0	0				-32
	0	1	0	1				-40
	0	1	1	0				-48
	0	1	1	1				-56
	1	0	0	0				-64
	1	0	0	1				-72
								MUTE
	1	0	1	X				
	1	1	X	X				
LEFT & RIGHT CHANNELS BOTH								
MSB							LSB	ZERO CROSS ATT. MODE
D7	D6	D5	D4	D3	D2	D1	D0	1 dB STEPS
0								ON
1								OFF

X = DON'T CARE  
 SPEAKER/RECORD ATTENUATION = 0dB ~ -79dB

RECORD AND RIGHT CHANNEL SPEAKER ATTENUATION SELECTION								
MSB							LSB	SPEAKER/RECORD ATT
D7	D6	D5	D4	D3	D2	D1	D0	1 dB STEPS
					0	0	0	0
					0	0	1	-1
					0	1	0	-2
					0	1	1	-3
					1	0	0	-4
					1	0	1	-5
					1	1	0	-6
					1	1	1	-7
								<b>8 dB STEPS</b>
	0	0	0	0				0
	0	0	0	1				-8
	0	0	1	0				-16
	0	0	1	1				-24
	0	1	0	0				-32
	0	1	0	1				-40
	0	1	1	0				-48
	0	1	1	1				-56
	1	0	0	0				-64
	1	0	0	1				-72
								<b>MUTE</b>
	1	0	1	X				
	1	1	X	X				

X = DON'T CARE

SPEAKER/RECORD ATTENUATION = 0dB ~ -79dB

VOICE CANCELLER/INPUT/REC OUT L & R SELECTION								
MSB							LSB	
D7	D6	D5	D4	D3	D2	D1	D0	VOICE CANCELLER
1							0	OFF
1							1	ON
								<b>INPUT MULTIPLEXER</b>
1			0	0	0	0		IN_2
1			0	1	0	1		IN_3
1			1	0	1	0		IN_4
1			1	1	1	1		IN_1
								<b>REC OUT "L"</b>
1			0	0				VAR 1 (3BAND)
1			0	1				VAR 2 (SURR)
1			1	0				VAR 3 (REAR)
1			1	1				FIX
								<b>REC OUT "R"</b>
1	0	0						VAR 1(3BAND)
1	0	1						VAR 2 (SURR)
1	1	0						VAR 3 (REAR)
1	1	1						FIX

SRS SPACE CONTROL: ATTENUATION SELECTION									
MSB							LSB	SPACE ATTENUATION	
D7	D6	D5	D4	D3	D2	D1	D0	1 dB STEPS	
					0	0	0	0	
					0	0	1	-1	
					0	1	0	-2	
					0	1	1	-3	
					1	0	0	-4	
					1	0	1	-5	
					1	1	0	-6	
					1	1	1	-7	
								<b>8 dB STEPS</b>	
		0	0	0				0	
		0	0	1				-8	
		0	1	0				-16	
		0	1	1				-24	
								<b>MUTE</b>	
		1	X	X	X	X	X		

X = DON'T CARE  
 SPEAKER/RECORD ATTENUATION = 0dB ~ -31dB

SRS CENTER CONTROL: ATTENUATION SELECTION									
MSB							LSB	CENTER ATTENUATION	
D7	D6	D5	D4	D3	D2	D1	D0	1 dB STEPS	
					0	0	0	0	
					0	0	1	-1	
					0	1	0	-2	
					0	1	1	-3	
					1	0	0	-4	
					1	0	1	-5	
					1	1	0	-6	
					1	1	1	-7	
								<b>8 dB STEPS</b>	
		0	0	0				0	
		0	0	1				-8	
		0	1	0				-16	
		0	1	1				-24	
								<b>MUTE</b>	
		1	X	X	X	X	X		
								<b>SRS INPUT</b>	
	0							NO SURROUND SIGNAL	
	1							SURROUND SIGNAL	
								<b>SRS SWITCH</b>	
0								SRS ON	
1								SRS OFF	

X = DON'T CARE  
 SPACE ATTENUATION = 0dB ~ -31dB  
 RECOMMENDED TO ATTENUATE -3dB IN INPUT ATTENUATION DURING "SRS OFF"  
 TO FULFILL SRS BYPASS MODE WHEN SRS FUNCTION IS USED



**POWER ON RESET**

SURROUND & OUT CONTROL+ EFFECT CONTROL	OFF + FIX + MAX ATTENUATION
SPEAKER/RECORD ATTENUATION L & R MODE	MUTE + ZERO CROSS ATT.OFF
INPUT ATTENUATION + REAR SWITCH	MAX ATTENUATION + ON
VOICE CANCELLER	OFF
INPUT	IN1
MIX SWITCH	NO MIX PIN
SRS SURROUND	OFF + MAX ATTENUATION
BASS & MIDDLE	2dB
TREBLE	0dB

**PIN DESCRIPTION**

**PINS:** L-OUT, R-OUT, RECOU-T-L, RECOU-T-R

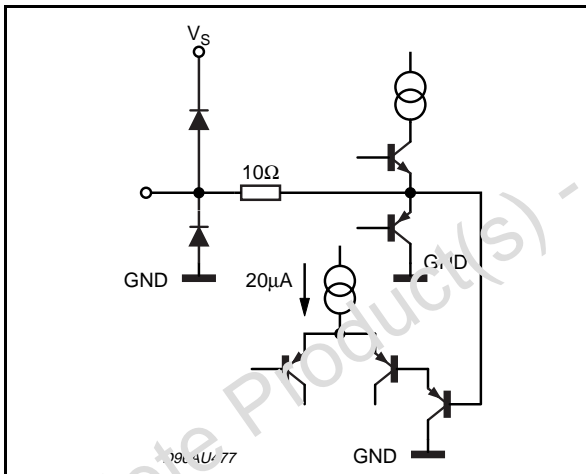

**PIN:** HP1

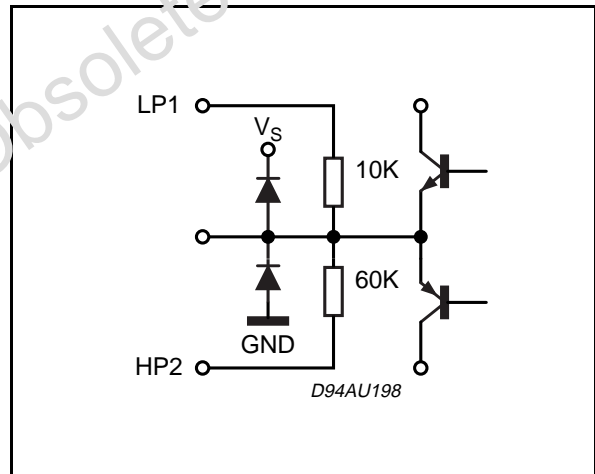

**PIN:** HP2

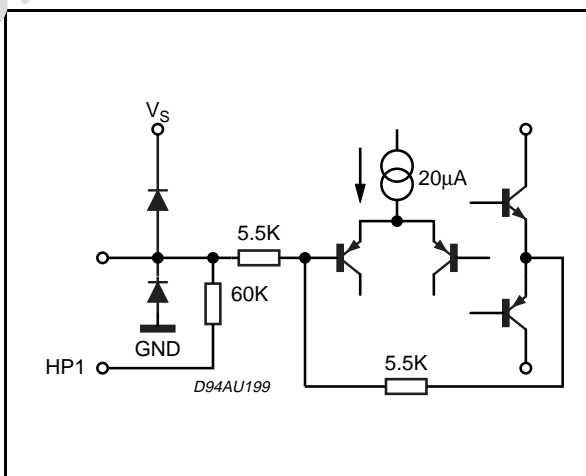

**PIN:** L-IN1, R-IN1, L-IN2, R-IN2, L-IN3, R-IN3, L-IN4, R-IN4,

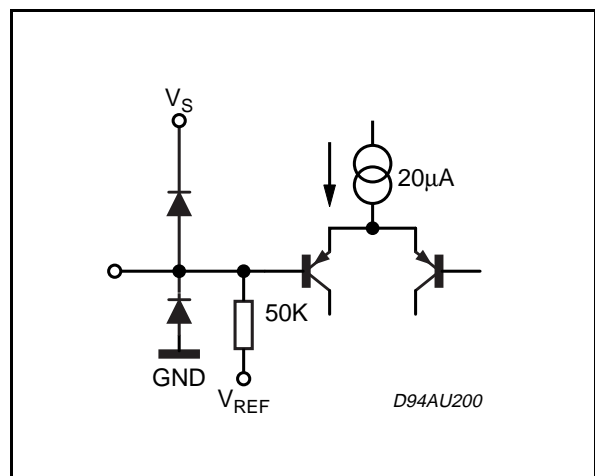



PIN: VAR-L, VAR-R,

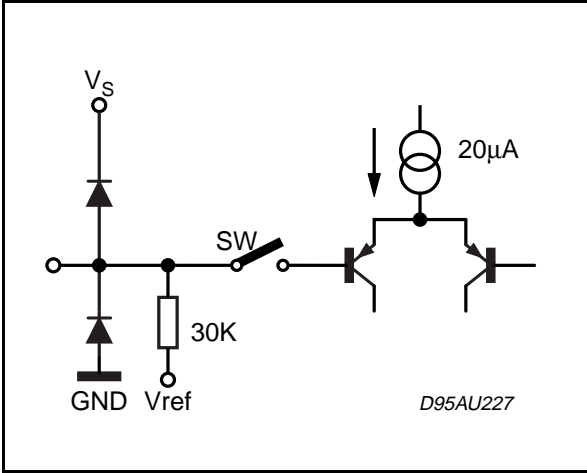

PIN: CREF

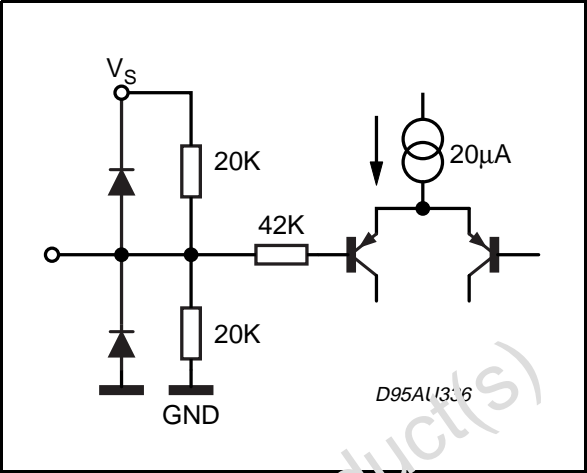

PIN: LP1

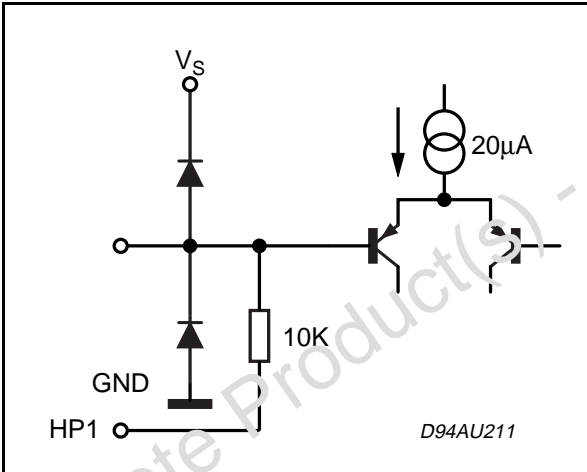

PIN: SCL, SDA

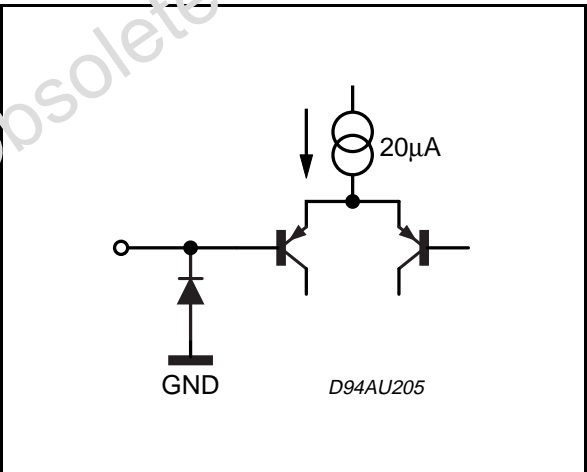

PIN: PS1, PS2, PS3, PS4, LP

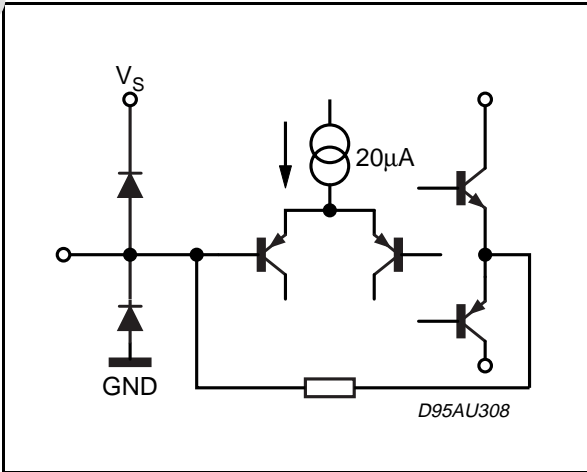

PIN: NETW2

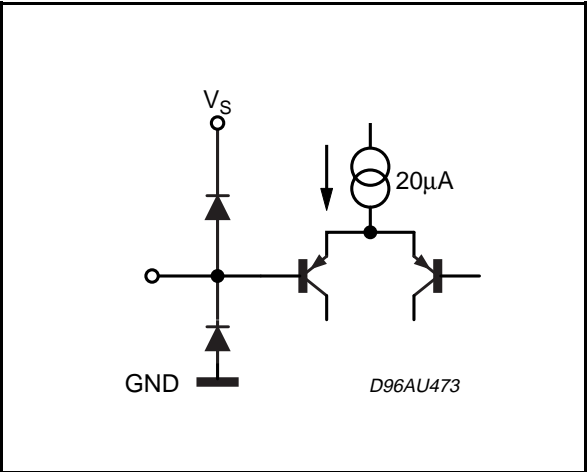

**TDA7464**

**PIN: BASSO-L, BASSO-R, NETW1**

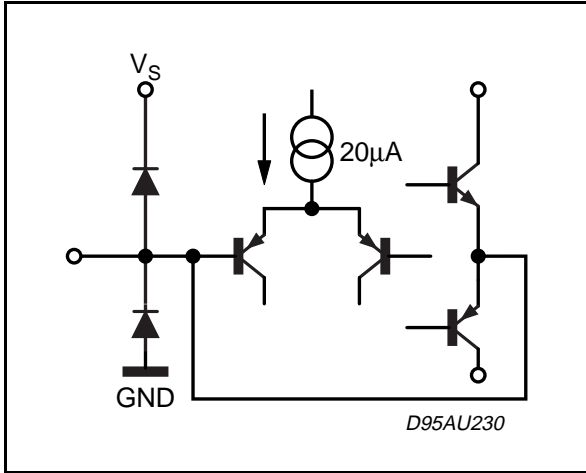

**PIN: BASS-LI, BASS-RI, MIDDLE-LI, MIDDLE-RI,**

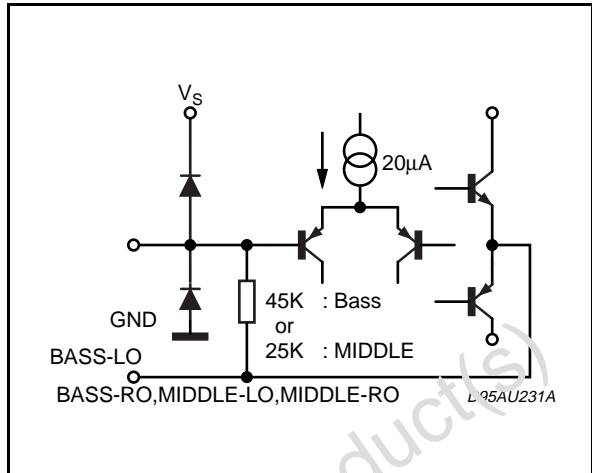

**PIN: BASS-LO, BASS-RO, MIDDLE-LO, MIDDLE-RO,**

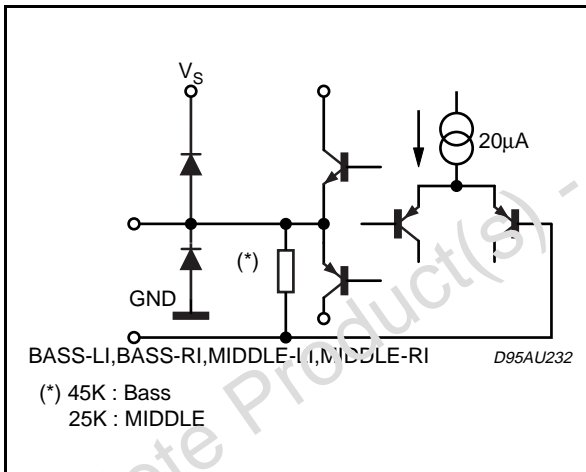

**PIN: TREBLE-L, TREBLE-R**

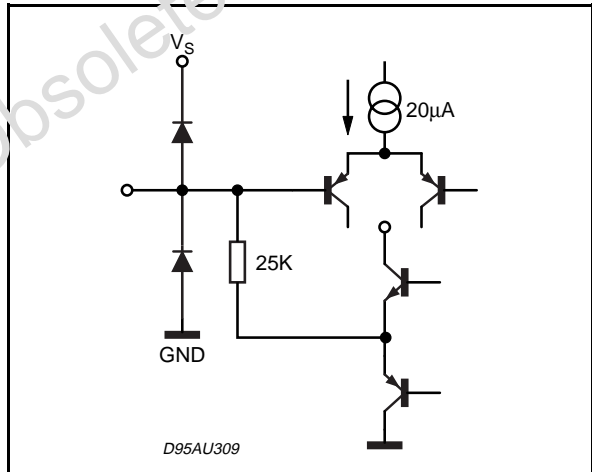

**PIN: VOUT REF**

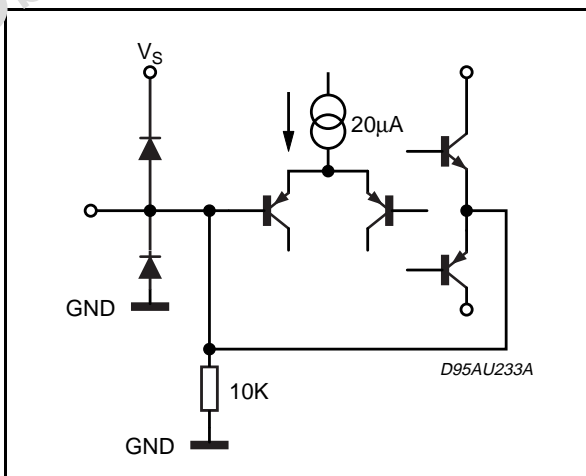

**PIN: NBLIN, NBRIN**

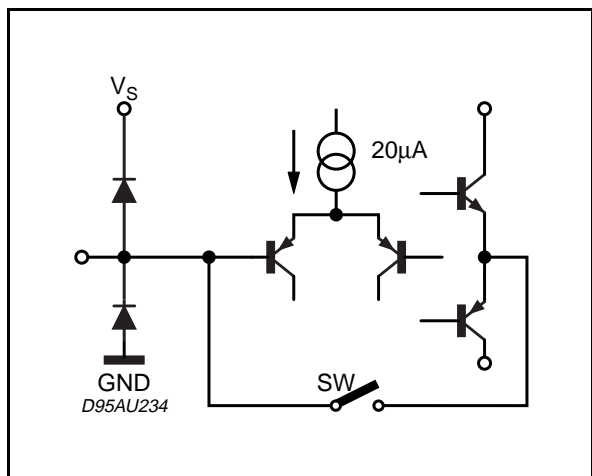

PIN: NBLO, NBRO

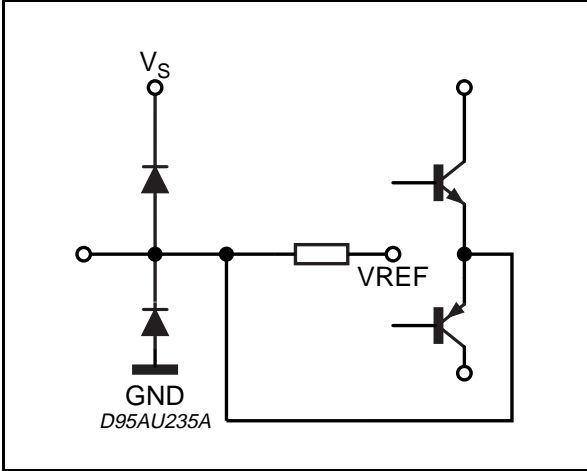

Obsolete Product(s) - Obsolete Product(s)

DIM.	mm			inch		
	MIN.	TYP.	MAX.	MIN.	TYP.	MAX.
A			1.60			0.063
A1	0.05		0.15	0.002		0.006
A2	1.35	1.40	1.45	0.053	0.055	0.057
B	0.30	0.37	0.45	0.012	0.014	0.018
C	0.09		0.20	0.004		0.008
D		12.00			0.472	
D1		10.00			0.394	
D3		8.00			0.315	
e		0.80			0.031	
E		12.00			0.472	
E1		10.00			0.394	
E3		8.00			0.315	
L	0.45	0.60	0.75	0.018	0.024	0.030
L1		1.00			0.039	
K	0°(min.), 3.5°(typ.), 7°(max.)					

**OUTLINE AND MECHANICAL DATA**

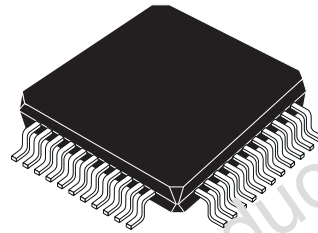

**TQFP44 (10 x 10)**

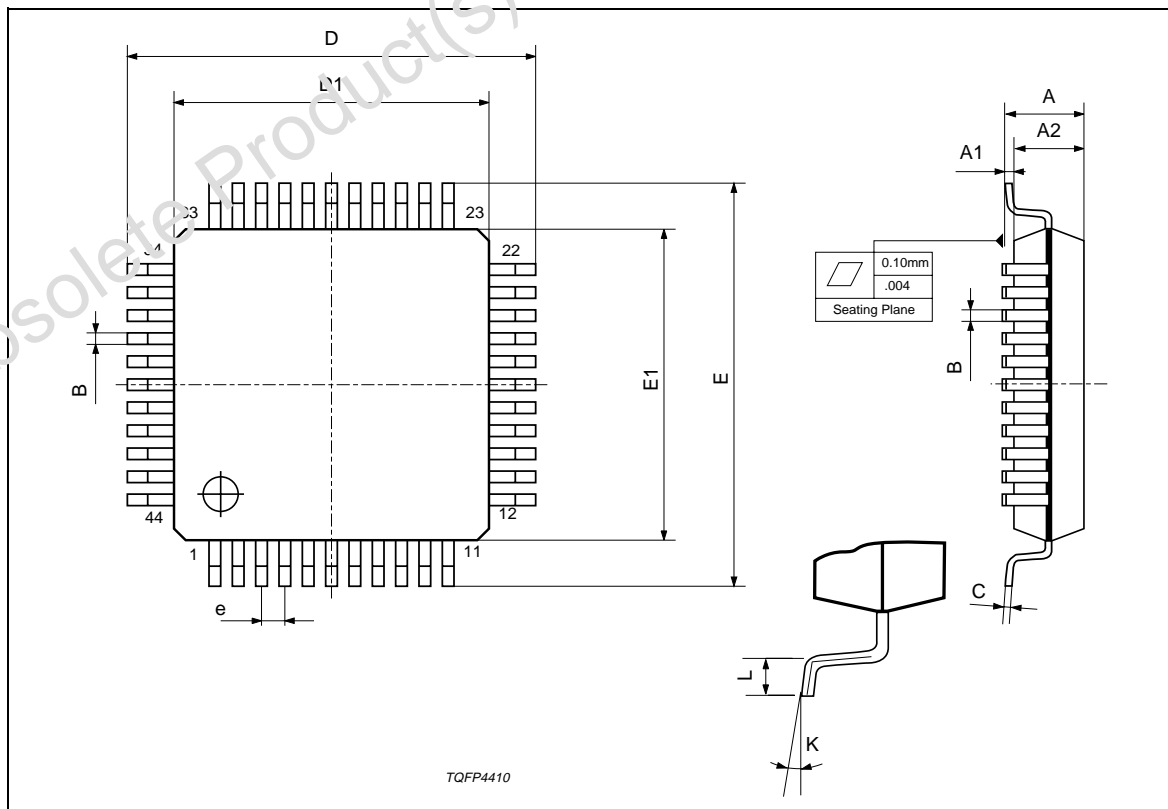

Obsolete Product(s) - Obsolete Product(s)

Information furnished is believed to be accurate and reliable. However, STMicroelectronics assumes no responsibility for the consequences of use of such information nor for any infringement of patents or other rights of third parties which may result from its use. No license is granted by implication or otherwise under any patent or patent rights of STMicroelectronics. Specifications mentioned in this publication are subject to change without notice. This publication supersedes and replaces all information previously supplied. STMicroelectronics products are not authorized for use as critical components in life support devices or systems without express written approval of STMicroelectronics.

The ST logo is a registered trademark of STMicroelectronics.

All other names are the property of their respective owners

© 2003 STMicroelectronics - All rights reserved

The Sound Retrieval System and **SRS (●)** are registered trademarks of SRS Labs, Inc.

**STMicroelectronics GROUP OF COMPANIES**

Australia - Belgium - Brazil - Canada - China - Czech Republic - Finland - France - Germany - Hong Kong - India - Israel - Italy - Japan - Malaysia - Malta - Morocco - Singapore - Spain - Sweden - Switzerland - United Kingdom - United States

[www.st.com](http://www.st.com)